

# GLACIER KING -20

By  **Polar King**  
INTERNATIONAL, INC.

## POWERTRAIN SPECIFICATIONS

Rear-wheel  
5-speed automatic transmission  
Fuel type: Ultra low sulfur diesel  
Tank capacity 26.4 gallons  
Electronically controlled direct injection  
Turbocharger and intercooler function  
Battery 12V/100 Ah, alternator 220 A  
BlueTEC SCR Diesel engine with AdBlue\*  
EPA/Carb 2010 Compliant  
6-cylinder, V72°  
4 valves per cylinder  
Displacement 2,987 cc  
188 hp at 3,800 rpm  
Rated torque 325 lb-ft at 1,400-2,400 rpm  
Partition with Sliding Door Package

## SELECTED OPTIONAL EQUIPMENT PACKAGES

Accessory Package  
Additional Battery Package  
Cargo Package  
Cold Climate Package  
Contractor Package  
Front Bench Seat Package  
Heavy Duty Front Axle Package  
High Idle Fixed Package  
High Idle Variable Package  
Interior Lighting Package  
Lighting Package  
Mobility Prep Package  
PARKTRONIC package  
Premium Package  
Rear Air Conditioning Package  
Rear Heating Packages I, II & III  
Security Package  
Suspension Packages  
Suspension Seating Package  
Trailer Hitch Package  
Window Packages I, II, III & IV  
Multi-function Wheel/Display Package

## GLACIER KING -20 VANS

VAN MODELS	2500 LOW ROOF	3500 HIGH ROOF	
	144" WB	170" WB EXT	
INTERIOR HEIGHT	54.06"	67.06"	
INTERIOR WIDTH	55.00"	50.50"	
INTERIOR LENGTH	105.50"	162.00"	
WIDTH AT WHEELBASE	50.00"	27.00"	
CARGO VOLUME (CUBIC FT.)	197	370	
TURNING DIAMETER (FT) WALL TO WALL	47.60"	54.60"	
FUEL TANK CAPACITY (GAL)	26.40	26.40	
GVWR	8,550	9,990	11,030
PAYLOAD	2,310	2,650	3,690

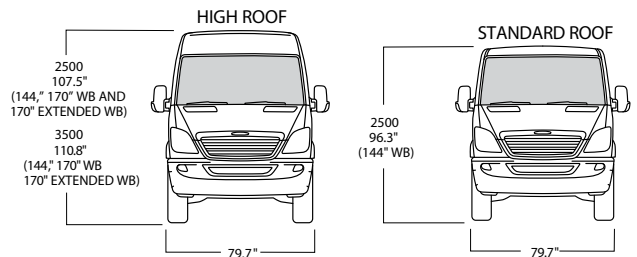
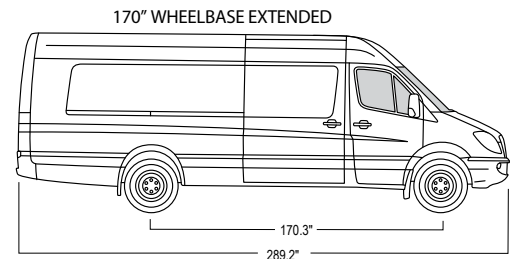
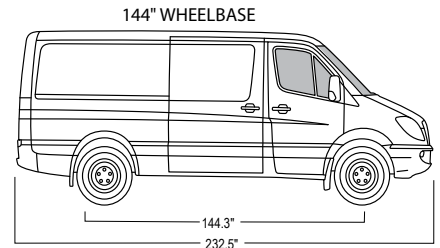

800-752-7178 [www.polar king.com](http://www.polar king.com)

\*Requires the use of ultra low sulfur diesel fuel. Freightliner Sprinter approves the use of B5 biodiesel (approved diesel fuel with a maximum 5% biodiesel content) in all BlueTEC engines. The only approved biodiesel content is one that meets ASTM D6751 specifications and has the oxidation stability necessary to prevent deposit-/corrosion-related damages to the system (min. 6h, proven by EN14112 method). Please see your service station for further information. If the B5 biodiesel blend does not clearly indicate that it meets the above standards, please do not use it. The Freightliner Sprinter New Vehicle Limited Warranty does not cover damage caused by non-Freightliner approved fuel standards.

No system, regardless of how advanced, can overcome the laws of physics or correct careless driving. Please always wear your seat belt. Performance is limited by available traction, which snow, ice and other conditions can affect. Always drive carefully, consistent with conditions. Best performance in snow is obtained with winter tires. Read Operator's Manual before towing. In some states, aftermarket trailer brakes are required. See dealer for details.

Warning: the forces of a deploying air bag can cause serious or fatal injuries to a child under age 13. See Operator's Manual for additional warnings and information on air bags, seat belts and child seats.

# GLACIER KING-20

By  **Polar King**  
INTERNATIONAL, INC.

## 144" WB Low Roof

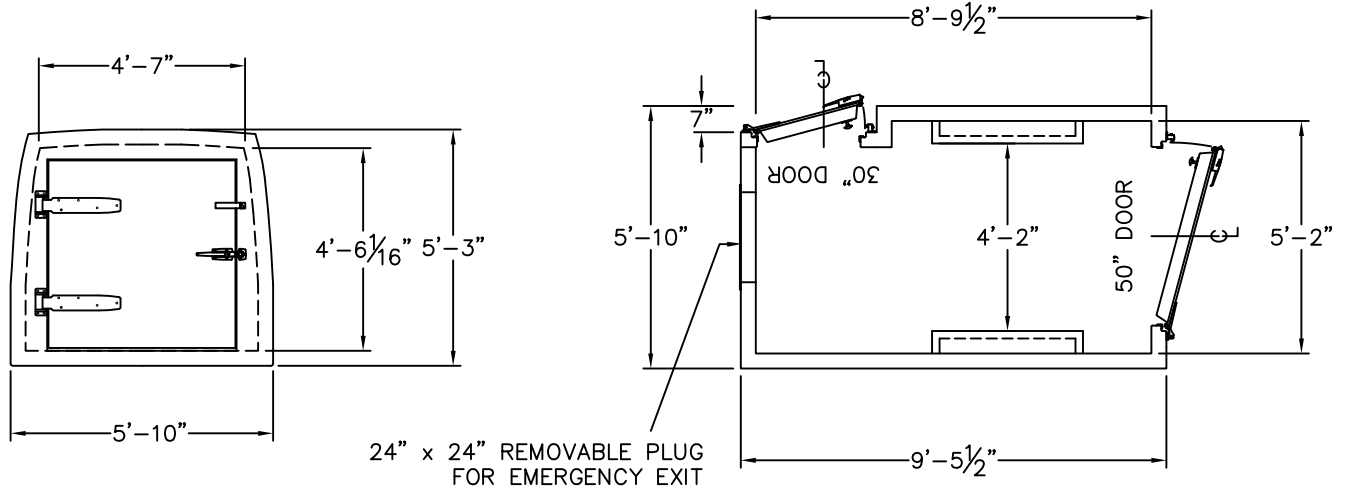

## 170" WBEXT High Roof

